

Device tag list

Heller_Dynam_Bed_2L2C

device tag	number	denomination	Type	Manufacturer	Heller no.	device tag	number	denomination	Type	Manufacturer	Heller no.
+CC-100.50	1	shut-off valve	HE-G1/2-LO 197134	Festo	01.093008	+H1-411.1-2	1	directional control valve	G1/8 4-Pin M12x1 401 130	Müller co-ax	01.102683
+CC-100.51	1	silencer	AMTE-M-LH-G1 1205865	Festo	01.112166	+H1-411.1-3	1	exhaust throttle	G1/8 238 04	Müller co-ax	01.097318
+CC-100.52	1	fastening angle	MS4-WP 532184	Festo	01.106320	+H1-411.1-4	1	exhaust throttle	G1/8 238 04	Müller co-ax	01.097318
+CC-100.53	1	filter pressure regulator	MS4-LFR-1/4-D6-CUV-A4 526489	Festo	01.109895	+MU-411.10	1	plastic pipe	18x1,5 PA12 HIPHL-nf DIN 73378	Stiefel	01.060217
+CC-100.53-1	1	filter element	MS4-LFP-C 534501	Festo	01.109899	+H1-411.11	1	hose line	DIN 20066-2SC25-NN-....-P 462-16-....	Parker	
+CC-100.54	1	pressure gauge	MA-50-10-1/4 359873	Festo	01.092062	+H1-417.11	1	hose line	DIN 20066-2SC16-NN-....-P 462-10-....	Parker	
+MU-100.60	1	plastic pipe	PA 8x1 1 820 712 102	AVENTICS	01.093303	+H1-440.1	1	directional control valve	5-VMK25 NC 2/2 G11/4 0-64bar, M12x1	Müller co-ax	02.001243
+MU-110.10	1	plastic pipe	PA 12x1,5 1 820 712 103	AVENTICS	01.093304	+H1-440.1-1	1	directional control valve	VMK 25 NC-Namur 0-64bar, G11/4	Müller co-ax	01.094865
+MU-110.11	1	check valve	NG6 G1/4 0 821 003 002	AVENTICS	01.031611	+H1-440.1-2	1	directional control valve	G1/8 4-Pin M12x1 401 130	Müller co-ax	01.102683
+MU-110.12	1	vacuum generator	ähnl EBP-240 R412007716	AVENTICS	01.100344	+H1-440.1-3	1	exhaust throttle	G1/8 238 04	Müller co-ax	01.097318
+MU-110.13	1	plastic pipe	PA 14x1,5 1 820 712 104	AVENTICS	01.093305	+H1-440.1-4	1	exhaust throttle	G1/8 238 04	Müller co-ax	01.097318
+MU-110.20	1	plastic pipe	PA 12x1,5 1 820 712 103	AVENTICS	01.093304	+H1-480.1	1	directional control valve	5-VMK25 NC 2/2 G11/4 0-64bar, M12x1	Müller co-ax	02.001243
+MU-110.21	1	check valve	RHZ12LREDO MD-CF ITL71 ST 1.4571	Parker	01.062111	+H1-480.1-1	1	directional control valve	VMK 25 NC-Namur 0-64bar, G11/4	Müller co-ax	01.094865
+H1-400.11	1	hose line	DIN 20066-2SC40-NN-....-P 462-40-....	Parker		+H1-480.1-2	1	directional control valve	G1/8 4-Pin M12x1 401 130	Müller co-ax	01.102683
+H1-410.1	1	flow control switch	SBU323 G1/2 75l/min	IFM Electronic	01.111533	+H1-480.1-3	1	exhaust throttle	G1/8 238 04	Müller co-ax	01.097318
+MU-410.2	1	hose line	DIN 20066-2SC16-NN-3750-P 462-10-3750	Parker	01.099742	+H1-480.1-4	1	exhaust throttle	G1/8 238 04	Müller co-ax	01.097318
+MU-410.3	1	check valve	RHZ18LREDO MD-CF ITL71 ST 1.4571	Parker	01.062112	+GOS-485.1	1	ball valve	BVG 4-3/4 C	Parker	01.084621
+MU-410.4	1	block		Heller Maschinenfabrik	00.788814	+GOS-485.2	1	ball valve	BVG 4-3/4 C	Parker	01.084621
+MU-410.5	1	hose line	DIN 20066-2SC10-NN- 630-P 462- 6- 630	Parker	01.099880	+GOS-485.3	1	ball valve	BVG 4-3/4 C	Parker	01.084621
+MU-410.6	1	hose line	DIN 20066-2SC10-NN- 630-P 462- 6- 630	Parker	01.099880	+GOS-485.4	1	ball valve	BVG 4-3/4 C	Parker	01.084621
+MU-410.8	1	directional control valve	5-VMK10 DR/NO 3/2 G1/2 0-80bar, M12x1	Müller co-ax	02.001914	+GOS-485.5	1	ball valve	BVG 4-3/4 C	Parker	01.084621
+MU-410.8-1	1	directional control valve	VMK 10 DR NO-Namur 0-80bar, G1/2	Müller co-ax	01.102636	+GMS-485.6	1	ball valve	BVG 4-3/4 C	Parker	01.084621
+MU-410.8-2	1	directional control valve	G1/8 4-Pin M12x1 401 130	Müller co-ax	01.102683	+GMS-485.7	1	ball valve	BVG 4-3/4 C	Parker	01.084621
+MU-410.8-3	1	exhaust throttle	G1/8 238 04	Müller co-ax	01.097318	+GMS-485.8	1	ball valve	BVG 4-3/4 C	Parker	01.084621
+MU-410.8-4	1	exhaust throttle	G1/8 238 04	Müller co-ax	01.097318	+GLS-490.1	1	coiled hose	HEL 09.03.30 DN12 2xG3/8a L=3300 blau	Stäubli	01.100442
+H1-410.11	1	hose line	DIN 20066-2SC16-NN-....-P 462-10-....	Parker		+GLS-490.2	1	wash gun	proficlean G1/2 Düse d=4mm 412.003 + 412-30	EWO	01.107273
+H1-411.1	1	directional control valve	5-VMK15 NC 2/2 G1/2 0-64bar, M12x1	Müller co-ax	02.001242	+H1-490.3	1	coupling	LW13 RBE 06.7813-IA	Stäubli	01.093166
+H1-411.1-1	1	directional control valve	VMK15NC, 2/2, 0-64bar G1/2	Müller co-ax	01.097317	+H1-490.4	1	coupling	G1/2 RBE 06.1153-IA	Stäubli	01.086801

Änderungen nur im CAD-Original!
Changes in CAD only!
Mudanças no original CAD somente!

© Copyright reserved - Gebr. HELLER Maschinenfabrik GmbH, D-72822 Nürtingen
Schutzvermerk nach DIN 34, beachten!
Attention! Observe DIN 34
Atenção! Atenção DIN 34

← &C+M/1		0.a →	
ART DER AENDERUNG/REVISION/DESCRIÇÃO DE ALTERAÇÃO		PROJ./PROJ./PROJ. 54802.00	
CAD-System		M-NR/M-NO/M-NO M54802	
ePLAN 2.2.5		TYP/TYPER/ TIPO H 10000 MC	
URSPPR./ORIG.		BENENNUNG/NAME/DENOMINAÇÃO	
ERS./REP.		KUNDE/CUSTOMER/CLIENTE	
ERS.D./REP.W.		Paccar, Columbus USA	
GEPR./CHECK./REG.		PLAN/PLAN/PLANO	
BEARB./CHG./ALT.		project	
GEZ./DRAWN/DES.		Machine	
04.04.2017		Document type	
AHFE/ZAJ		Mounting position	
04.04.2017		Page name	
AHFE/ZAJ		WERKSTÜCK/ PART/PEÇA	
		MP.05480200_F	
		=M54802	
		&K coolant diagram	
		0	
		A3	

Device tag list

Heller_Dynam_Bed_2L2C

device tag	number	denomination	Type	Manufacturer	Heller no.
+H1-490.5	1	ball valve	BVG 4-3/8 L	Parker	01.094579

Änderungen nur im CAD-Original!
 Changes in CAD only!
 Mudanças no original CAD somente!

© Copyright reserved - Gebr. HELLER Maschinenfabrik GmbH, D-72622 Nürtingen
 Schutzvermerk nach DIN 34 beachten!
 Attention! Observe DIN 34
 Atenção! Atente DIN 34

← 0

+H1/1 →

ART DER AENDERUNG/REVISION/DESCRIÇÃO DE ALTERAÇÃO		Index	ZONE/ZONA	DATUM/DATE	NAME/NOME	PROJ./PROJ/ PROJ.	<div style="text-align: center; font-weight: bold; font-size: 1.2em;">HELLER</div>	KUNDE/CUSTOMER/CLIENTE	PLAN/PLAN/PLANO
CAD-System		URSPPR./ORIG.	GEPR./CHECK./REG.			M-NR/M-NO/ M-NO		Paccar, Columbus USA	project
ePLAN 2.2.5		ERS./REP.	BEARB./CHG./ALT.	04.04.2017	AHFE/ZAJ	H 10000 MC	BENENNUNG/NAME/DENOMINAÇÃO <div style="text-align: center;">Device tag list coolant</div>	INV-NR/INV-NO/NO-INV	Machine
		ERS.D./REP.W.	GEZ./DRAWN/DES.	04.04.2017	AHFE/ZAJ	WERKSTÜCK/ PART/PEÇA			Document type
								Mounting position	0.a
								Page name	

Änderungen nur im CAD-Original!
Changes in CAD only!
Mudanças no original CAD somente!

© Copyright reserved - Gebr. HELLER Maschinenfabrik GmbH, D-72622 Nürtingen
Schutzvermerk nach DIN 34 beachten!
Attention! Observe DIN 34
Atenção! Atenção DIN 34

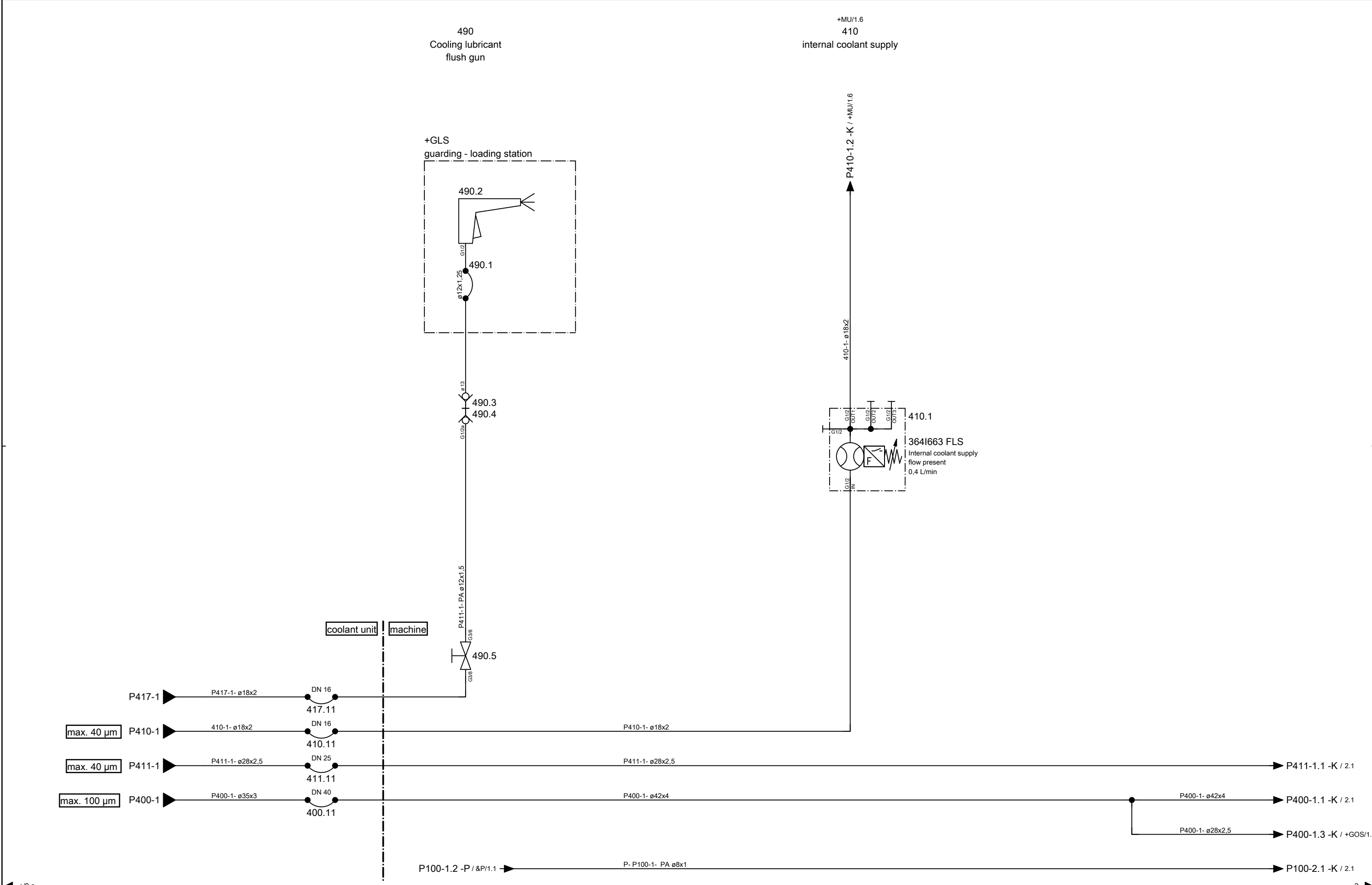

ART DER AENDERUNG/REVISION/DESCRIÇÃO DE ALTERAÇÃO		Index	ZONE/ZONA	DATUM/DATE	NAME/NOME	PROJ./PROJ/ PROJ.	54802.00	HELLER	KUNDE/CUSTOMER/CLIENTE	PLAN/PLAN/PLANO	
CAD-System		URSPR./ORIG.	GEPR./CHECK./REG.			M-NR/M-NO/ M-NO	M54802		Paccar, Columbus USA	project	MP.05480200_F
ePLAN 2.2.5		ERS./REP.	BEARB./CHG./ALT.	04.04.2017	AHFE/ZAJ	TYP./TYPE/ TIPO	H 10000 MC	coolant diagram	INV-NR/INV-NO/NO-INV	Machine	=M54802
		ERS.D./REP.W.	GEZ./DRAWN/DES.	14.03.2016	AHFE/HOP	WERKSTÜCK/ PART/PEÇA				Document type	&K
									Mounting position	+H1	HELP1
									Page name	1	

Heller_2L

Änderungen nur im CAD-Original!
Changes in CAD only!
Mudanças no original CAD somente!

© Copyright reserved - Gebr. HELLER Maschinenfabrik GmbH, D-72822 Nürtingen
Schutzvermerk nach DIN 34 beachten!
Attention! Observe DIN 34
Atenção! Atente DIN 34

413
Cooling lubricant
multi-spindle head

+MU/1.8
411
Cooling lubricant
spindle nozzles

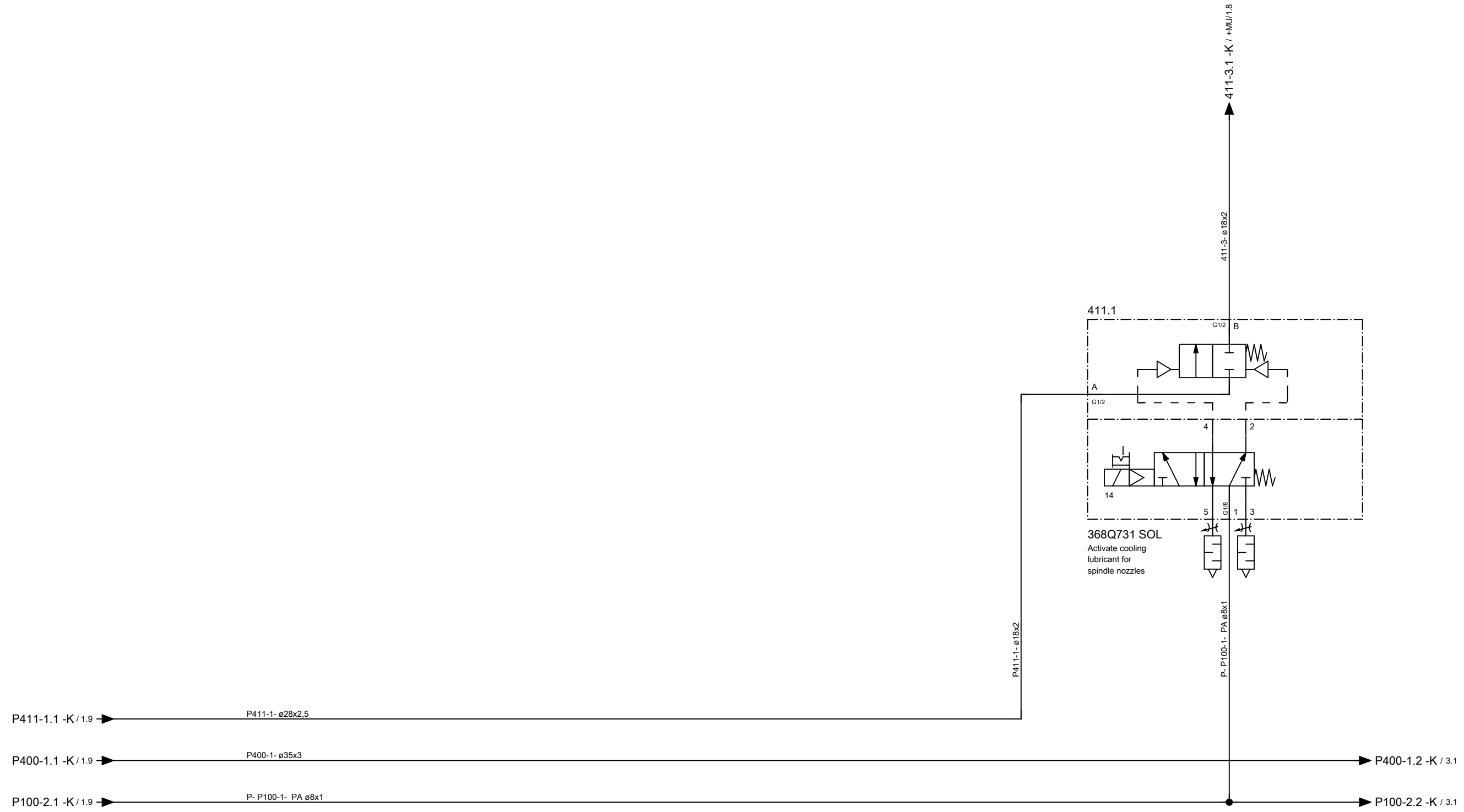

← 1 3 →

ART DER AENDERUNG/REVISION/DESCRIÇÃO DE ALTERAÇÃO	Index	ZONE/ZONA	DATUM/DATE	NAME/NOME
CAD-System	URSPR./ORIG.	GEPR./CHECK./REG.		
ePLAN 2.2.5	ERS./REP.	BEARB./CHG./ALT.	04.04.2017	AHFE/ZAJ
	ERS.D./REP.W.	GEZ./DRAWN/DES.	14.03.2016	AHFE/HOP

PROJ./PROJ/PROJ.	54802.00
M-NR/M-NO/M-NO	M54802
TYP/TYPE/TIPO	H 10000 MC
WERKSTÜCK/PART/PEÇA	

HELLER

coolant diagram

KUNDE/CUSTOMER/CLIENTE	Paccar, Columbus USA
INV-NR/INV-NO/NO-INV	

PLAN/PLAN/PLANO	project	MP.05480200_F
	Machine	=M54802
	Document type	&K coolant diagram
	Mounting position	+H1 HELP1
	Page name	2

Heller_2L

Änderungen nur im CAD-Original!
Changes in CAD only!
Mudanças no original CAD somente!

© Copyright reserved - Gebr. HELLER Maschinenfabrik GmbH, D-72822 Nürtingen
Schutzvermerk nach DIN 34 beachten!
Attention! Observe DIN 34
Atenção! Atenção DIN 34

431
Cooling lubricant
tool cleaning, low
pressure, rack-type magazine

+GMA/1.2
440
Flushing
of workpiece loading station

+GMA/1.5
480
Flush
workpiece
in work area

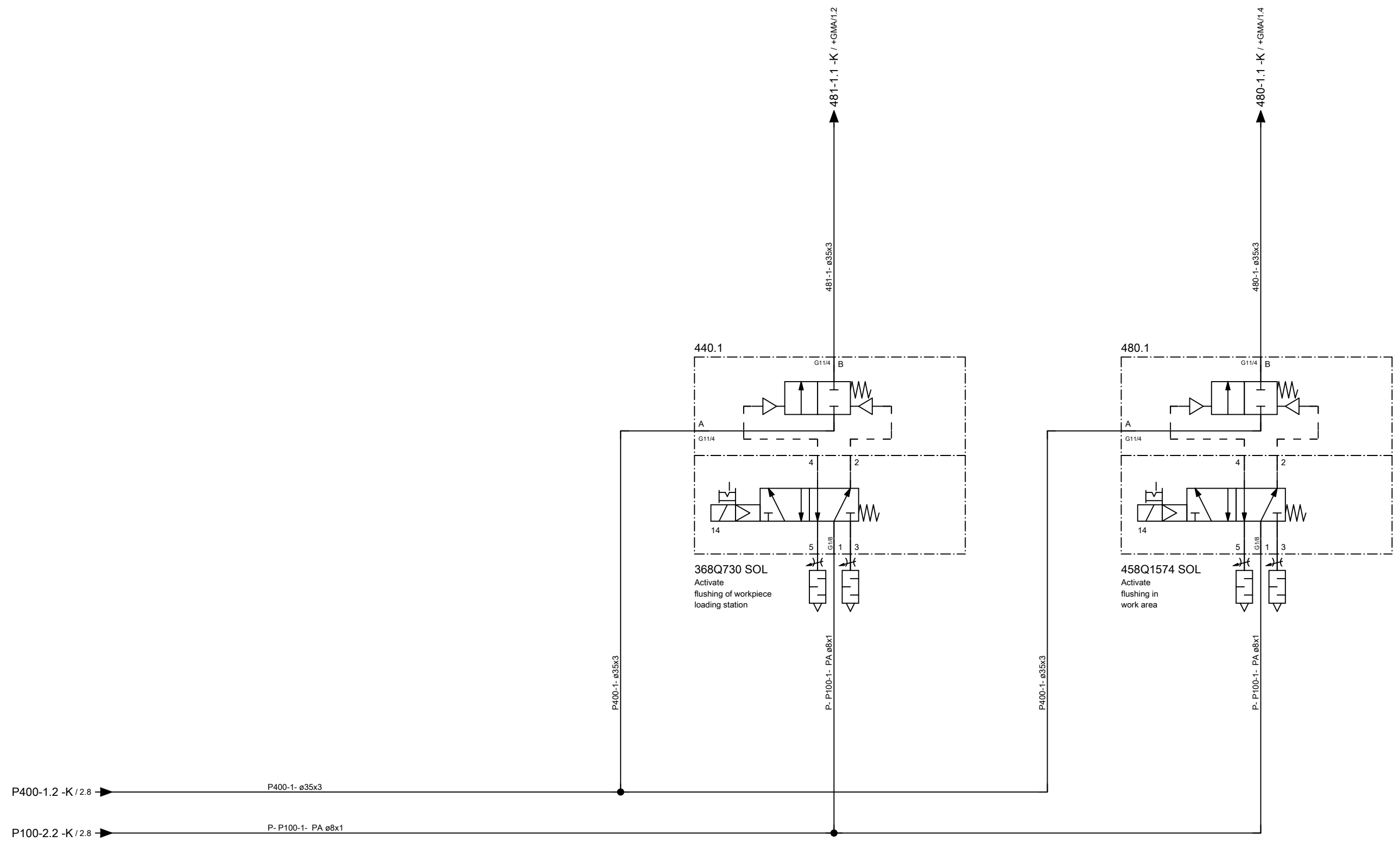

P400-1.2 -K / 2.8 → P400-1- ø35x3

P100-2.2 -K / 2.8 → P- P100-1- PA ø8x1

← 2

+MU/1 →

ART DER AENDERUNG/REVISION/DESCRIÇÃO DE ALTERAÇÃO				Index	ZONE/ZONA	DATUM/DATE	NAME/NOME	PROJ./PROJ/ PROJ.	54802.00	HELLER	KUNDE/CUSTOMER/CLIENTE	PLAN/PLAN/PLANO		
CAD-System				URSPPR./ORIG.	GEPR./CHECK./REG.			M-NR/M-NO/ M-NO	M54802		Paccar, Columbus USA	project	MP.05480200_F	
ePLAN 2.2.5				ERS./REP.	BEARB./CHG./ALT.	04.04.2017	AHFE/ZAJ	TYP/TYPE/ TIPO	H 10000 MC			Machine	=M54802	
				ERS.D./REP.W.	GEZ./DRAWN/DES.	14.03.2016	AHFE/HOP	WERKSTÜCK/ PART/PEÇA			BENENNUNG/NAME/DENOMINAÇÃO	coolant diagram	Document type	&K coolant diagram
										INV-NR/INV-NO/NO-INV		Mounting position	+H1 HELP1	
												Page name	3	

Änderungen nur im CAD-Original!
Changes in CAD only!
Mudanças no original CAD somente!

© Copyright reserved - Gebr. HELLER Maschinenfabrik GmbH, D-72622 Nürtingen
Schutzvermerk nach DIN 34 beachten!
Attention! Observe DIN 34
Atenção! Atenção DIN 34

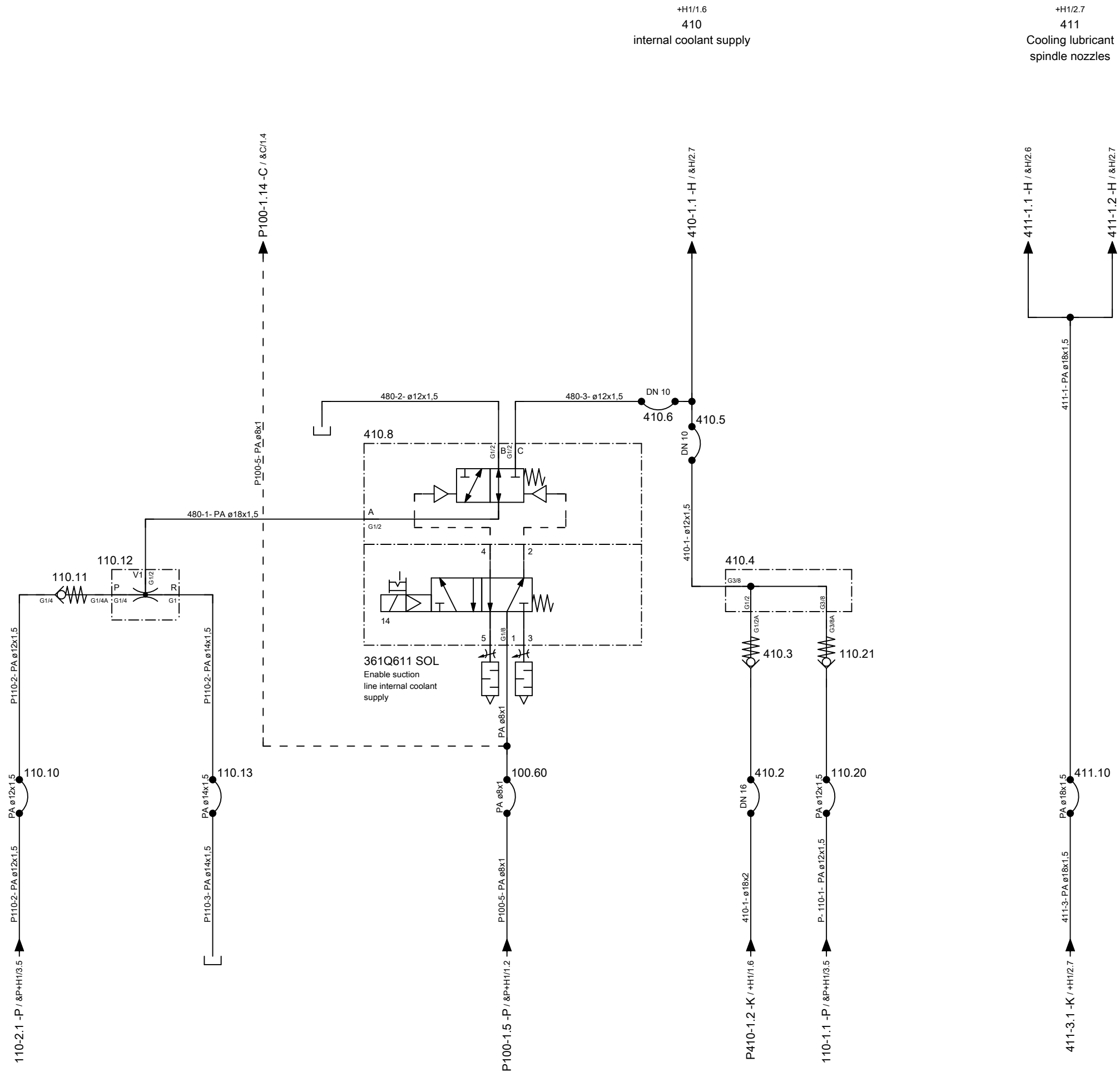

← +H1/3 +GOS/1 →

ART DER AENDERUNG/REVISION/DESCRIÇÃO DE ALTERAÇÃO		Index	ZONE/ZONA	DATUM/DATE	NAME/NOME	PROJ./PROJ./PROJ.	HELLER	KUNDE/CUSTOMER/CLIENTE	PLAN/PLAN/PLANO	
CAD-System		URSPR./ORIG.	GEPR./CHECK./REG.			M-NR/M-NO/ M-NO		Paccar, Columbus USA	project	MP.05480200_F
ePLAN 2.2.5		ERS./REP.	BEARB./CHG./ALT.	04.04.2017	AHFE/ZAJ	M54802			Machine	=M54802
		ERS.D./REP.W.	GEZ./DRAWN/DES.	14.03.2016	AHFE/HOP	H 10000 MC	BENENNUNG/NAME/DENOMINAÇÃO	Document type	&K coolant diagram	
								Mounting position	+MU unit	
							coolant diagram	Page name	1	

Änderungen nur im CAD-Original!
Changes in CAD only!
Mudanças no original CAD somente!

© Copyright reserved - Gebr. HELLER Maschinenfabrik GmbH, D-72622 Nürtingen
Schutzvermerk nach DIN 34 beachten!
Attention! Observe DIN 34
Atenção! Atenção DIN 34

operating side

magazine side

Flushing below
the Z-cover

Flush X-axis

Flush
Z-Axis bed pan

Flush
guard panels

Flush
frontside

Flush X-axis

Flush
Z-Axis bed pan

Flush
guard panels

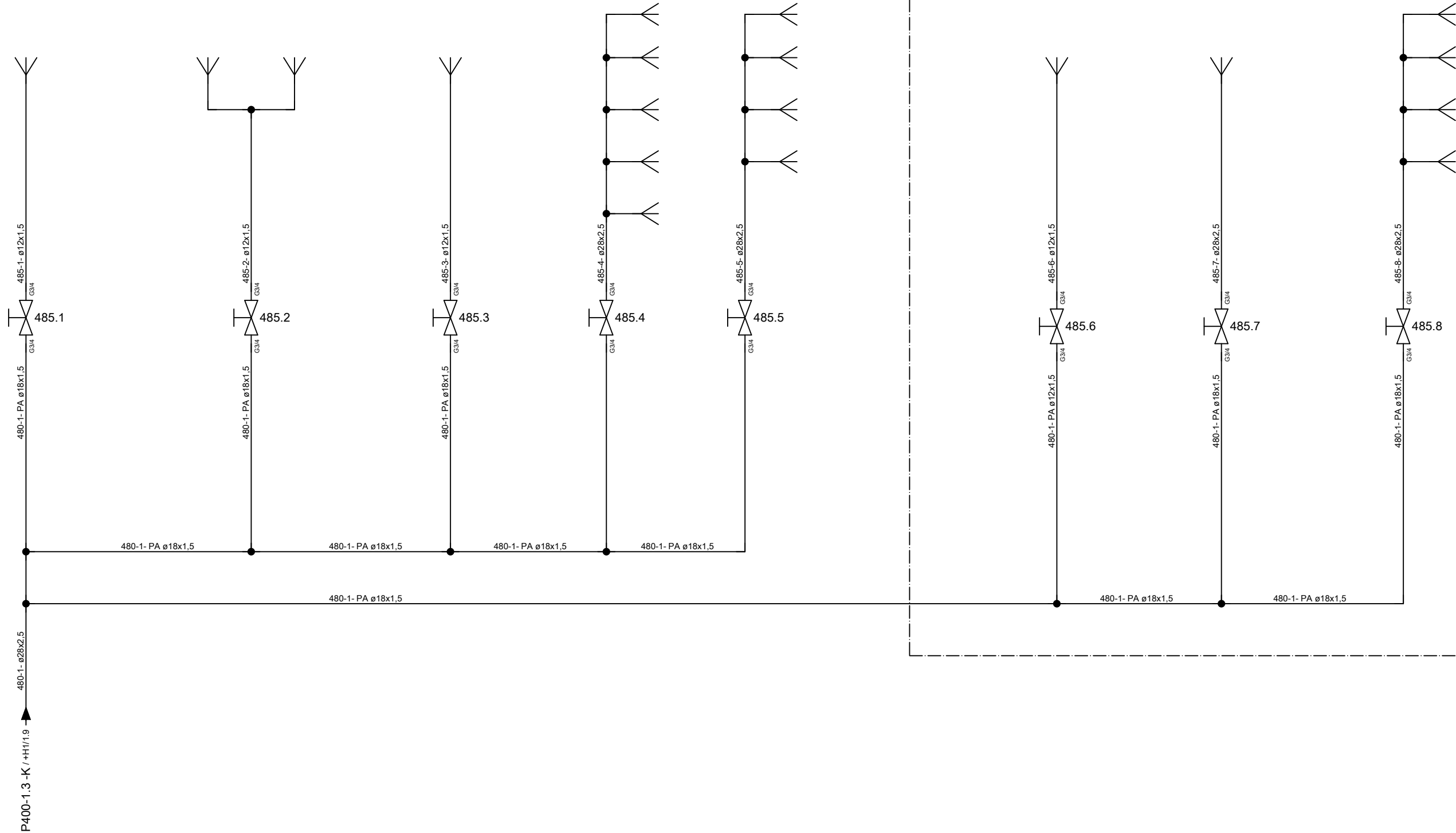

← +MU/1

+GMA/1 →

ART DER AENDERUNG/REVISION/DESCRIÇÃO DE ALTERAÇÃO		Index	ZONE/ZONA	DATUM/DATE	NAME/NOME	PROJ./PROJ/ PROJ.	54802.00	HELLER	KUNDE/CUSTOMER/CLIENTE	PLAN/PLAN/PLANO	
CAD-System		URSPR./ORIG.	GEPR./CHECK./REG.	BEARB./CHG./ALT.	AHFE/ZAJ	M-NR/M-NO/ M-NO	M54802		Paccar, Columbus USA	project	MP.05480200_F
ePLAN 2.2.5		ERS./REP.	GEZ./DRAWN/DES.	14.03.2016	AHFE/HOP	TYP/TYPE/ TIPO	H 10000 MC	coolant diagram	INV-NR/INV-NO/NO-INV	Machine	=M54802
		ERS.D./REP.W.				WERKSTÜCK/ PART/PEÇA				Document type	&K coolant diagram
									Mounting position	+GOS guarding - operating side	
									Page name	1	

Heller_2L

Änderungen nur im CAD-Original!
Changes in CAD only!
Mudanças no original CAD somente!

© Copyright reserved - Gebr. HELLER Maschinenfabrik GmbH, D-72622 Nürtingen
Schutzvermerk nach DIN 34 beachten!
Attention! Observe DIN 34
Atenção! Atente DIN 34

+H1/3.5
440
Flushing
of workpiece loading station

+H1/3.7
480
Flush
workpiece
in work area

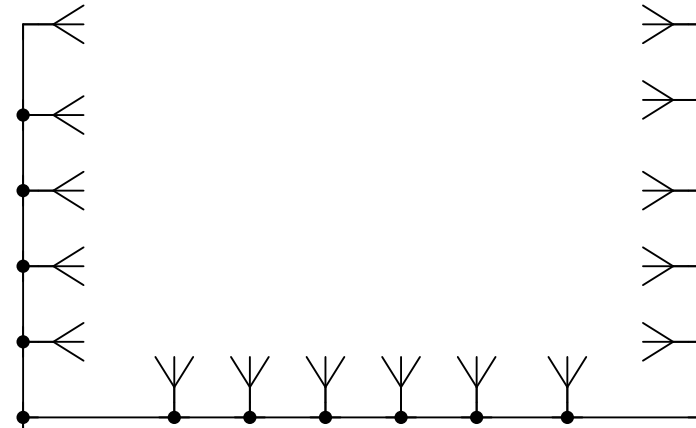
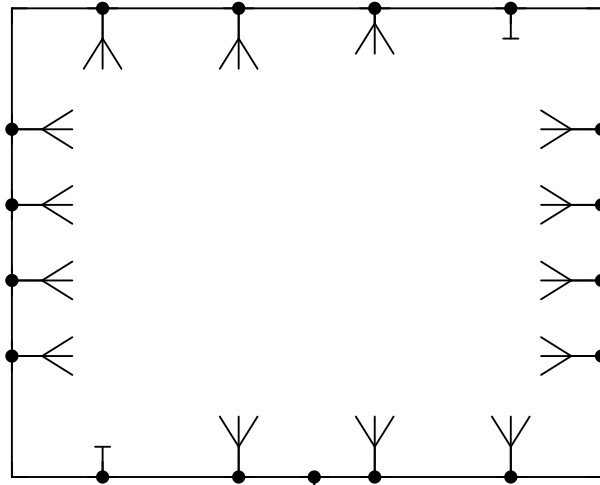

← +GOS/1

+CC/1 →

ART DER AENDERUNG/REVISION/DESCRIÇÃO DE ALTERAÇÃO		Index	ZONE/ZONA	DATUM/DATE	NAME/NOME	PROJ./PROJ/ PROJ.	54802.00	HELLER	KUNDE/CUSTOMER/CLIENTE	PLAN/PLAN/PLANO	
CAD-System		URSPR./ORIG.	GEPR./CHECK./REG.			M-NR/M-NO/ M-NO	M54802		Paccar, Columbus USA	project	MP.05480200_F
ePLAN 2.2.5		ERS./REP.	BEARB./CHG./ALT.	04.04.2017	AHFE/ZAJ	TYP/TYPE/ TIPO	H 10000 MC	coolant diagram	INV-NR/INV-NO/NO-INV	Machine	=M54802
		ERS.D./REP.W.	GEZ./DRAWN/DES.	14.03.2016	AHFE/HOP	WERKSTÜCK/ PART/PEÇA				Document type	&K coolant diagram
									Mounting position	+GMA guarding - machining area	
									Page name	1	
										A3	

Heller_2L

Änderungen nur im CAD-Original!
Changes in CAD only!
Mudanças no original CAD somente!

© Copyright reserved - Gebr. HELLER Maschinenfabrik GmbH, D-72822 Nürtingen
Schutzvermerk nach DIN 34 beachten!
Attention! Observe DIN 34
Atenção! Atente DIN 34

&P+H1/1.3
100
air supply
recirculating station

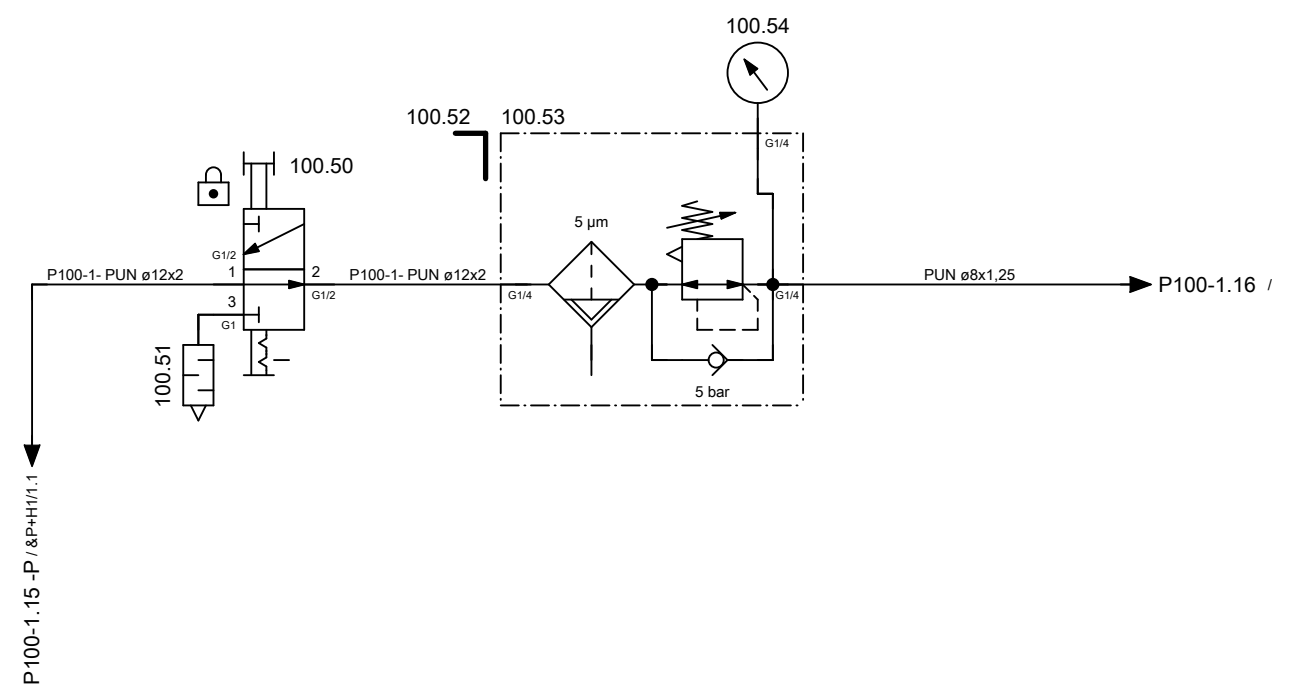

← +GMA/1

ART DER AENDERUNG/REVISION/DESCRIÇÃO DE ALTERAÇÃO				Index	ZONE/ZONA	DATUM/DATE	NAME/NOME	PROJ./PROJ/ PROJ.	54802.00	HELLER	KUNDE/CUSTOMER/CLIENTE	PLAN/PLAN/PLANO	
CAD-System				URSPPR./ORIG.	GEPR./CHECK./REG.			M-NR/M-NO/ M-NO	M54802		Paccar, Columbus USA	project	MP.05480200_F
ePLAN 2.2.5				ERS./REP.	BEARB./CHG./ALT.	14.07.2016	AHFE/ZAJ	TYP/TYPE/ TIPO	H 10000 MC	coolant diagram	INV-NR/INV-NO/NO-INV	Machine	=M54802
				ERS.D./REP.W.	GEZ./DRAWN/DES.	14.03.2016	AHFE/ZAJ	WERKSTÜCK/ PART/PEÇA			13.504083	Document type	&K coolant diagram
											Mounting position	+CC chip conveyor	
											Page name	1	

Heller_2L